



*A journey
of partnership, participation,
performance and pleasure*

Teresa Stanley, WaterSafe Auckland
Jan Taylor, WaterSafe Auckland
Ian Calhaem, Board of Advisors, WaterSafe Auckland

Supported by ratepayers of
AUCKLAND

Background



- School pools are closing
- Time and transport costs to community pools
- Aquatic skills is in the NZ Curriculum
- Most aquatics education ends at year 8
- Professional Development - Most teachers incorrectly think ***aquatics = swimming***

Supported by ratepayers of
AUCKLAND

Becoming Aquatically Educated



Water safety knowledge

Supported by ratepayers of
AUCKLAND

The Portable Pool



Supported by ratepayers of
AUCKLAND

Filling the pool



Supported by ratepayers of
AUCKLAND

Water circulation

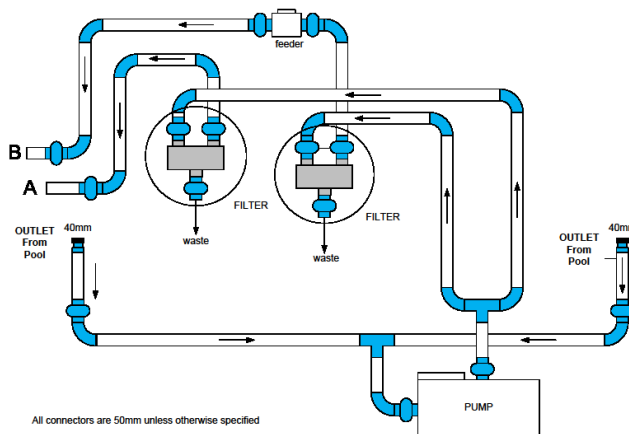

Supported by ratepayers of
AUCKLAND

Compliance and layers of protection



Supported by ratepayers of
AUCKLAND

KiwiSport Project



Government funded initiative for school age sport, funded through Regional Sport Trusts

- increase number participating in organised sport
- increase availability and accessibility of sport opportunities
- develop skills that enable them to participate confidently in sport.



Supported by ratepayers of
AUCKLAND

KiwiSport Project



To deliver a multi-dimensional aquatic education programme to selected schools

- Learning to swim
- Survival skills
- Developing critical thinking
- Transferring these learnings to experiences to participation in aquatic activities



Supported by ratepayers of
AUCKLAND

KiwiSport Project



School	Roll Size	# Classes	Own Pool
Glen Taylor School	330	15	Y
Glenbrae School	149	6	Y
Glen Innes Primary	173	8	Y
St Pius X School	165	7	N
St Patricks School	144	7	N
Point England School	510	20	N
Ruapotaka School	199	10	Y
Tamaki Primary	196	8	N
Panmure Bridge School	211	8	N
Stanhope Road School	516	26	Y
Bailey Road School	436	19	Y
Sylvia Park School	330	14	N
Destiny School	120	6	N
Sommerville Special School	188		N



Supported by ratepayers of
AUCKLAND



Integrated Aquatic Programme for Year 0-8

"Water is fun - make it a safe playground for everyone"

Yr 0	Sequential Development Needs	Yr 8	Websites
	SailSafe [T] [P]		
	Waterwise [T] [P]		
	Safe Boating [T]		
	Surf Aware [T] [P]		
	BeachEd [T] [P]		
	Surf Smart [T]		
	Surf Sense [T]		
	Surf Safety [T]		
Essential & Survival	SwimStart (SwimSafe) [P]		
Thinking & Safety	WaterSense [T]		
	Bubbles to Buoyancy [T] [P]		
	H2O Here We Go [T] [P]		
	In at the Deep End [P]		

Theory [T] Practical [P]



Buoyancy Aids



One School

- Teacher Development – Aquatic Education and State Kiwi Swim Safe
- Number of sessions during school – 260 (roll 510 – decile 1 school)
- 15 sessions each student (usually 20)
- Before school / lunchtime – 52 sessions
- Early childhood and parents – 12 sessions

“The ‘portable pool’ project has been hugely successful at our school- not only improving our students’ skills around swimming but increasing their water confidence and giving them strategies to use if they should find themselves in difficulty. It has also given them an opportunity to experience new activities such as Triathlon, snorkelling and life saving.”

*Barbara Ala’alatoa
Principal, Sylvia Park School*

Building a water safety culture through education



www.watersafe.org.nz

Supported by ratepayers of
AUCKLAND